

# PLIANT BELLOWS™

Expansion Joints  
ENRICHED FOR FLEXIBILITY

by  
Flexoresist Technologies Pvt. Ltd.

ENRICHED  
FOR



FLEXIBILITY

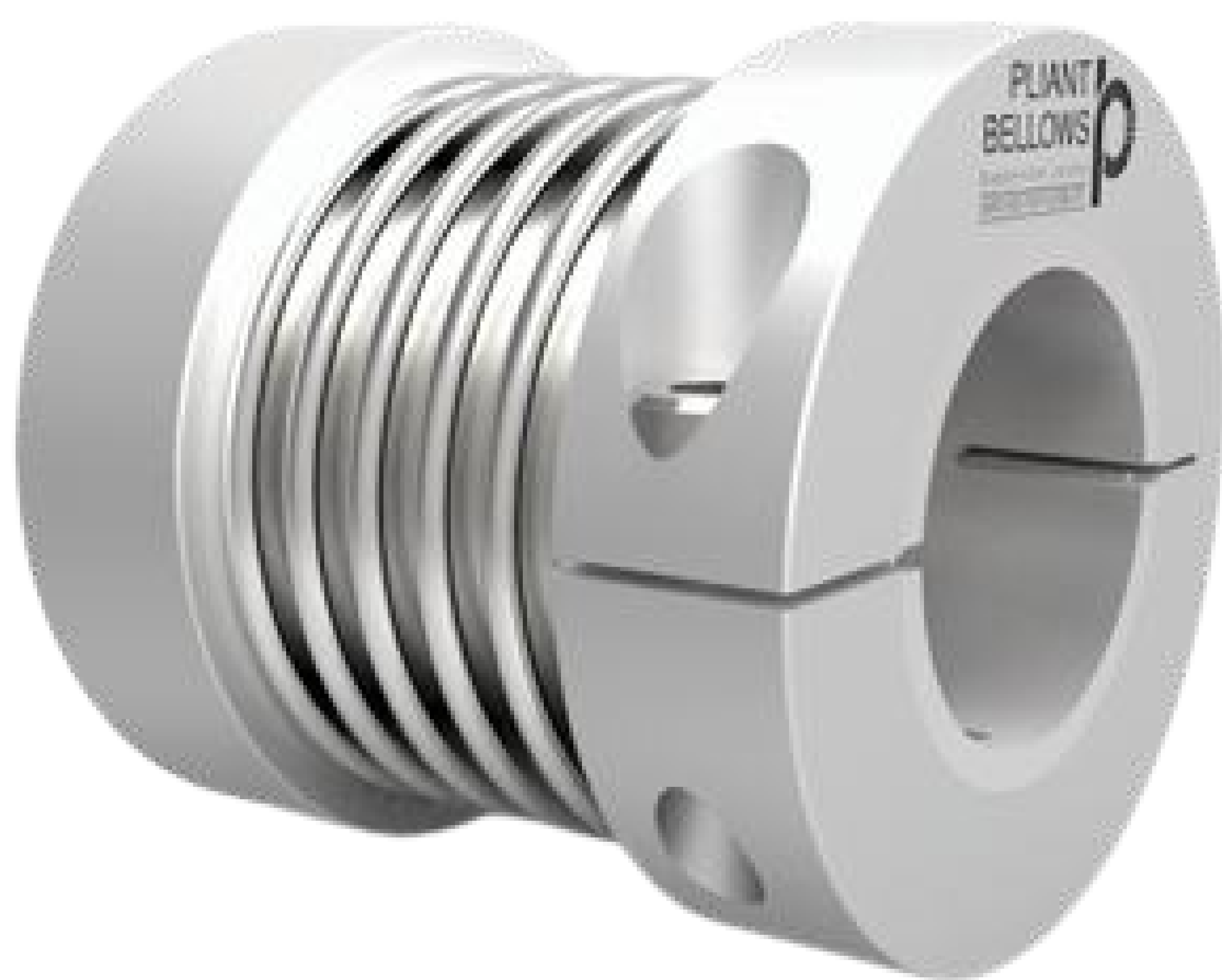

METAL BELLOW COUPLINGS

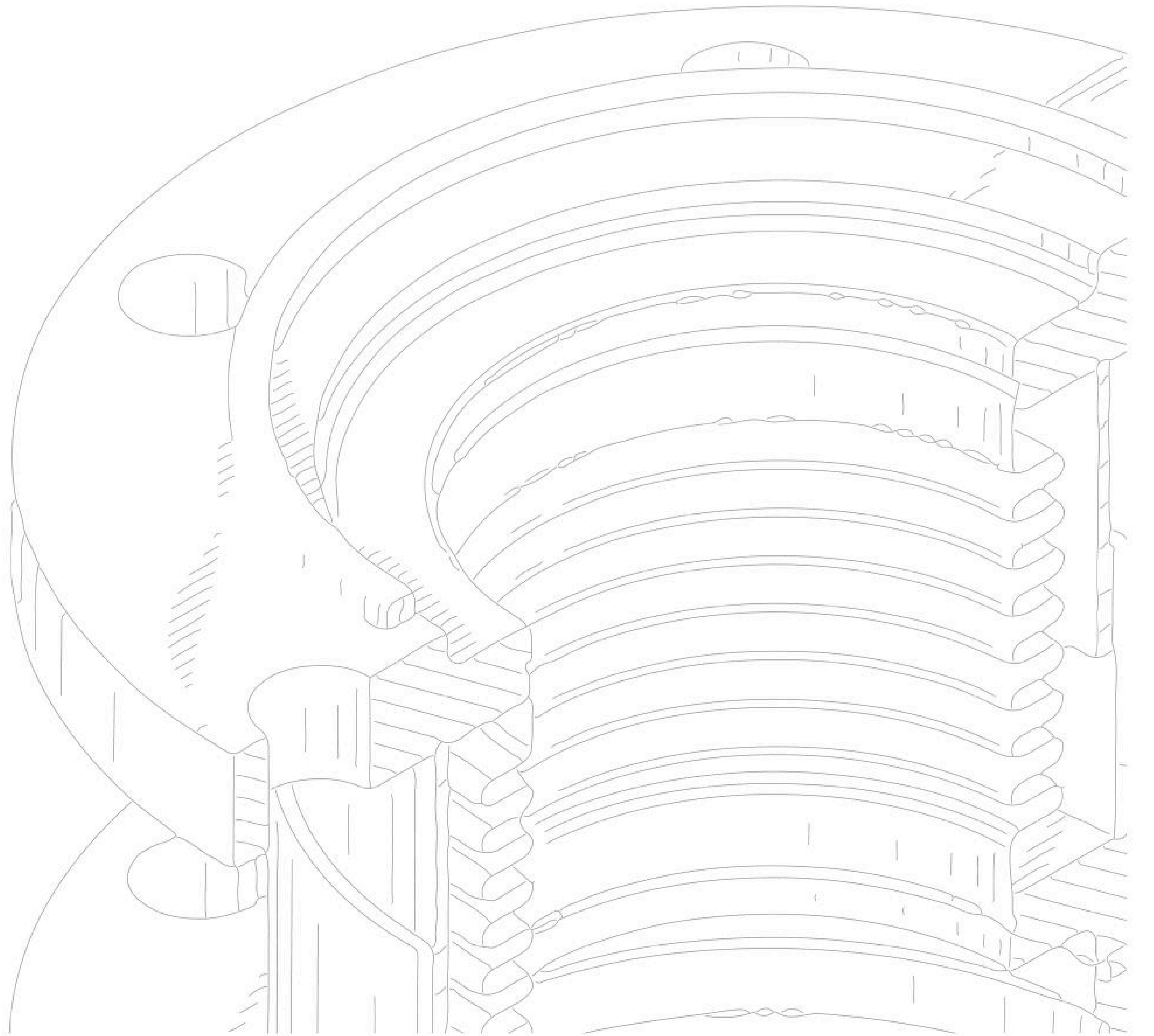
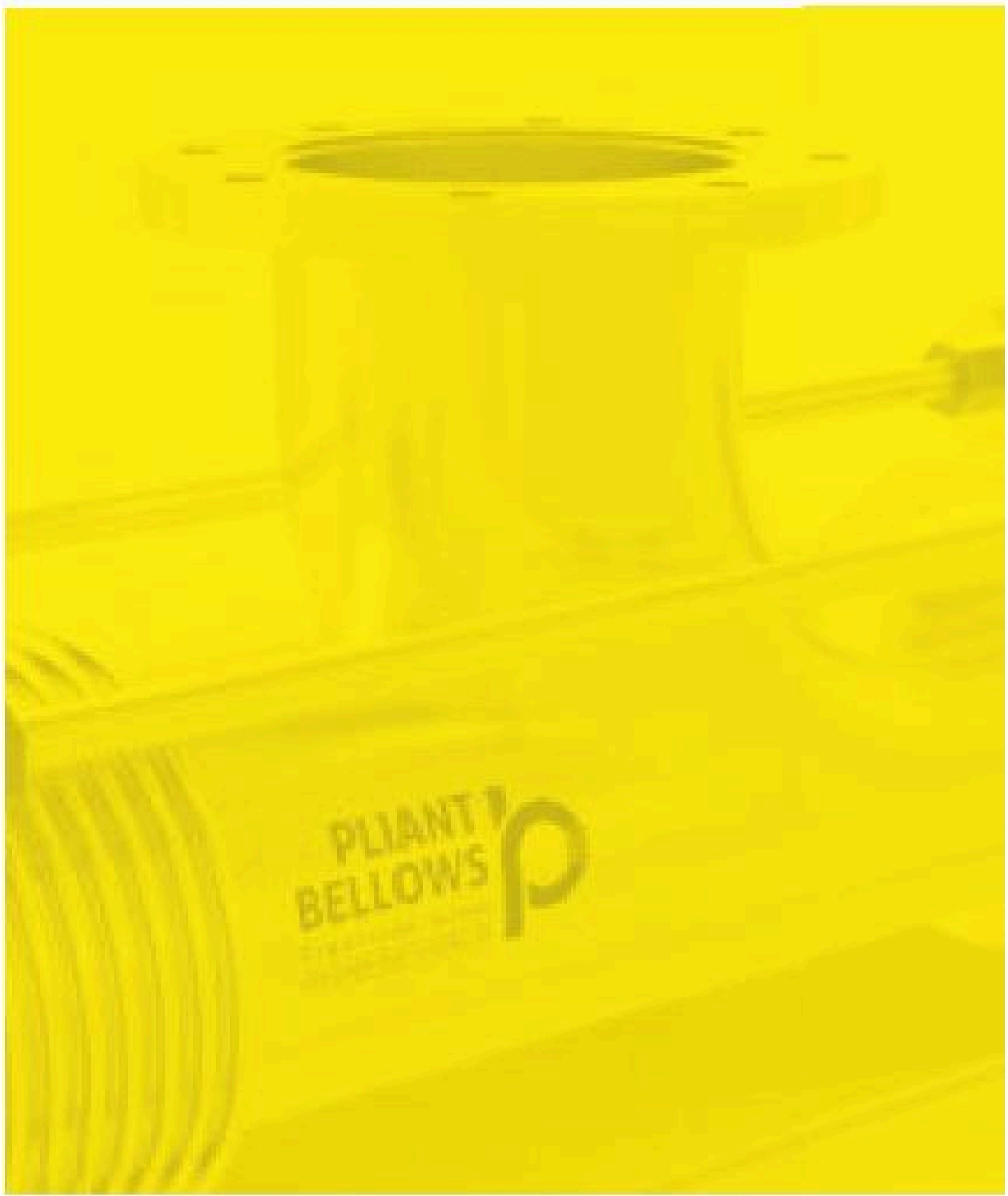
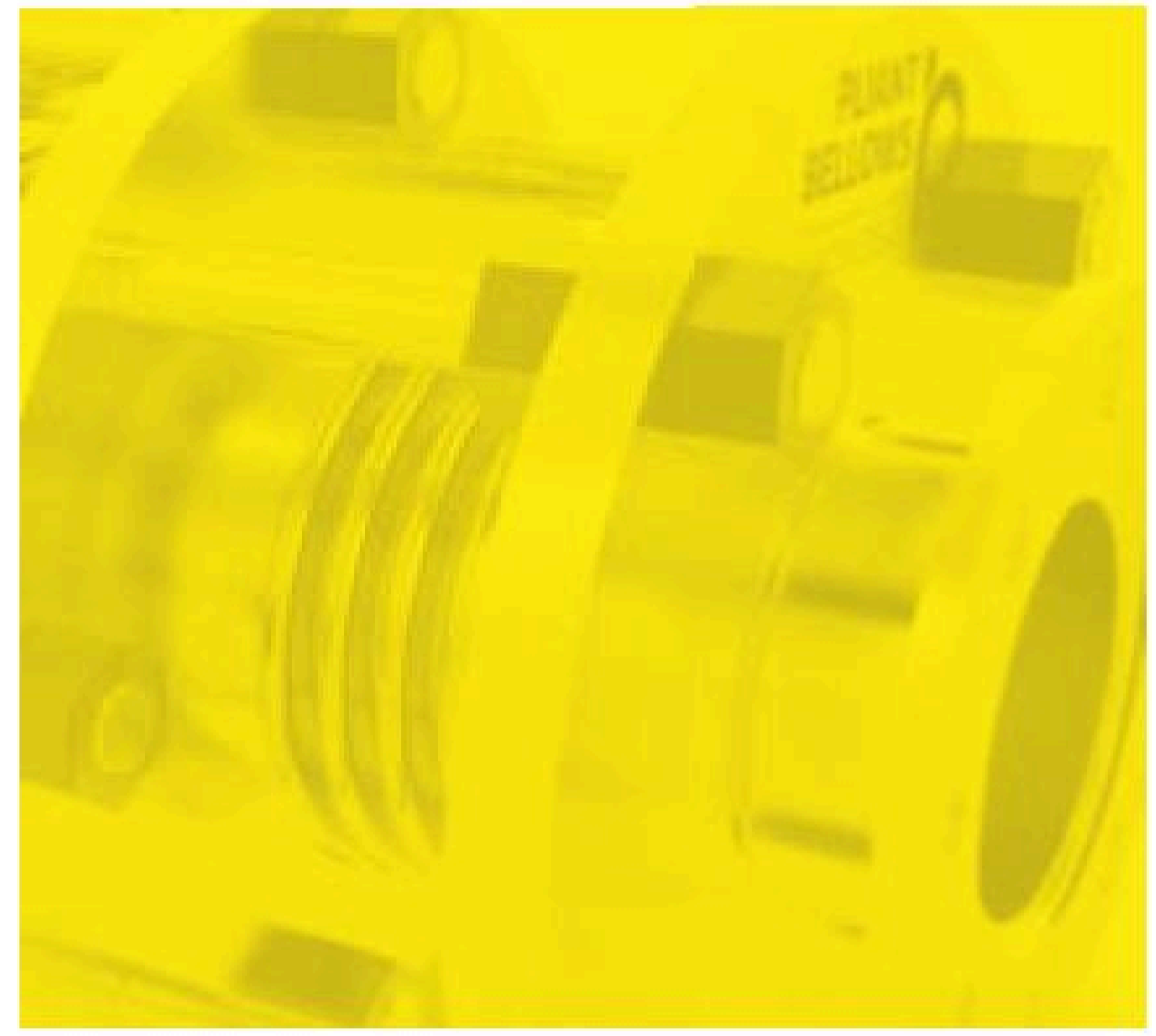

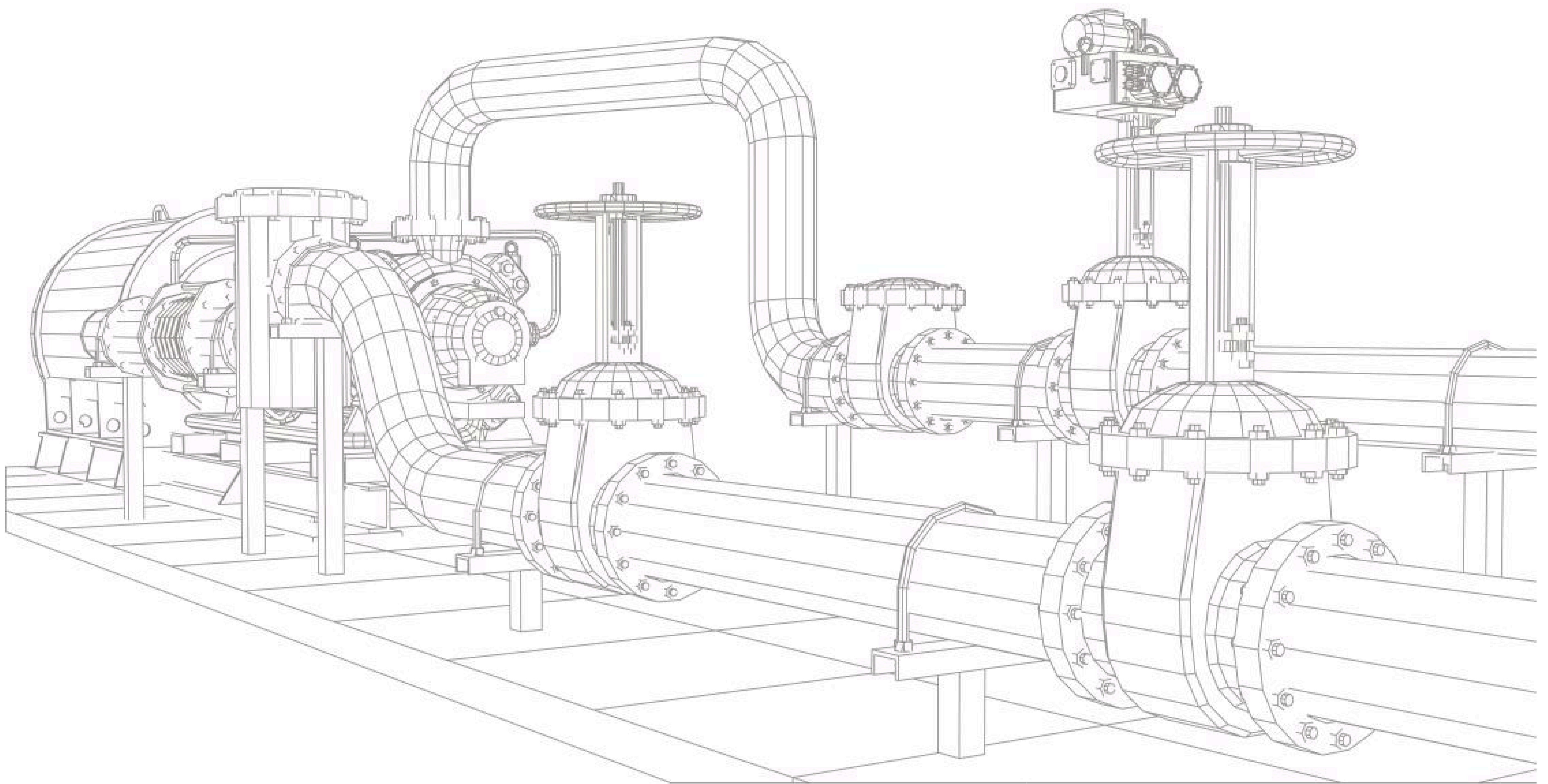

## About Company

Flexoresist Technologies Pvt. Ltd. is a pioneering entity in the Indian market, specializing in the design and manufacturing of innovative products previously domestically. Founded with the vision to fill the gap in the Indian market, Flexoresist embarked on its journey under the leadership of Mr. Anand Uttarkar, Industrial engineer with a Master's degree from Texas, USA.

### **Mission and Vision:**

At Flexoresist, our mission is to revolutionize the Indian engineering landscape by introducing cutting-edge products that cater to the evolving needs of various industries. We envision a future where indigenous innovation drives technological advancement and economic growth.under the brand name, "Pliant Bellows".

### **Technical Excellence:**

With a culture deeply rooted in technical proficiency, Flexoresist prioritizes excellence in

design, engineering, and manufacturing processes

### **Customer Satisfaction:**

We are committed to exceeding customer expectations by delivering superior quality products and unparalleled service.

### **Innovation:**

We are committed to exceeding customer expectations by delivering superior quality products and unparalleled service.

### **Products:**

Flexoresist stands as a leading authority in the design and manufacturing of the following products:

1. Metal Bellows and Expansion Joints
2. Metal O rings, C Rings, Spring Energized C Rings

## Business Philosophy & Strengths

- As the CEO and GM are technically qualified, the general orientation of the company is towards technical excellence .The work culture has also been developed accordingly.
- The company implements Kaizen (Continuous Improvement) and 5S techniques to keep the entire system up to the mark.
- To facilitate all the above at the operational level, experienced and qualified manpower has been employed.
- The company has endeavored to meet and achieve the quality standards set by its customers.



## Systems And Certificates

Kwalitiy Products is an ISO 9001:2015 certified company and is well supported by ERP software to maintain documentation. The entire tracking process, from incoming raw materials to dispatch, is maintained on a regular basis.

The company has been approved by Rolls Royce for it's engineering needs.

# Leadership



## **Mr. Anand Uttarkar**

### **CEO**

Mr. Anand Uttarkar, the CEO, is a highly qualified engineer holding an M.S. degree in Industrial Engineering from Texas, USA. With over 23 years of experience in the industry, he has been instrumental in driving the organization toward excellence. His extensive expertise has contributed significantly to achieving the highest quality standards while implementing cost-effective solutions. Under his strategic leadership and vision, the organization has not only enhanced its operational efficiency but has also received numerous prestigious accolades and certifications, reinforcing its commitment to quality and innovation.



# Technology

## Hydroforming Machine

The hydroforming machine is designed by U.S. designers and manufactured to international quality standards. Bellows formed through the hydroforming process have a uniform structure with high dimensional accuracy. In a single step, corrugations are created across the entire metal bellow, significantly enhancing productivity. The properties achieved through hydroforming are far superior to those of mechanically drawn bellows.

Metal bellows can be manufactured with a single ply or multiple plies, offering excellent flexibility, pressure tightness, and minimal wall thickness.

Diameter range	[mm]	15 – 600
Ply thickness	[mm]	0.2 – 4
Tube length	[mm]	up to 1000
Internal pressure	[bar]	up to 340
Total Power	[HP]	25
Forming Time	[sec]	<60

## High-Performance Coupling

- Backlash-Free Torque Transmission
- High Torsional Rigidity
- Minimal Mass Moment of Inertia
- High Misalignment Compensation Capability
- High Performance-to-Cost Ratio due to simple construction
- Quick and Simple Installation

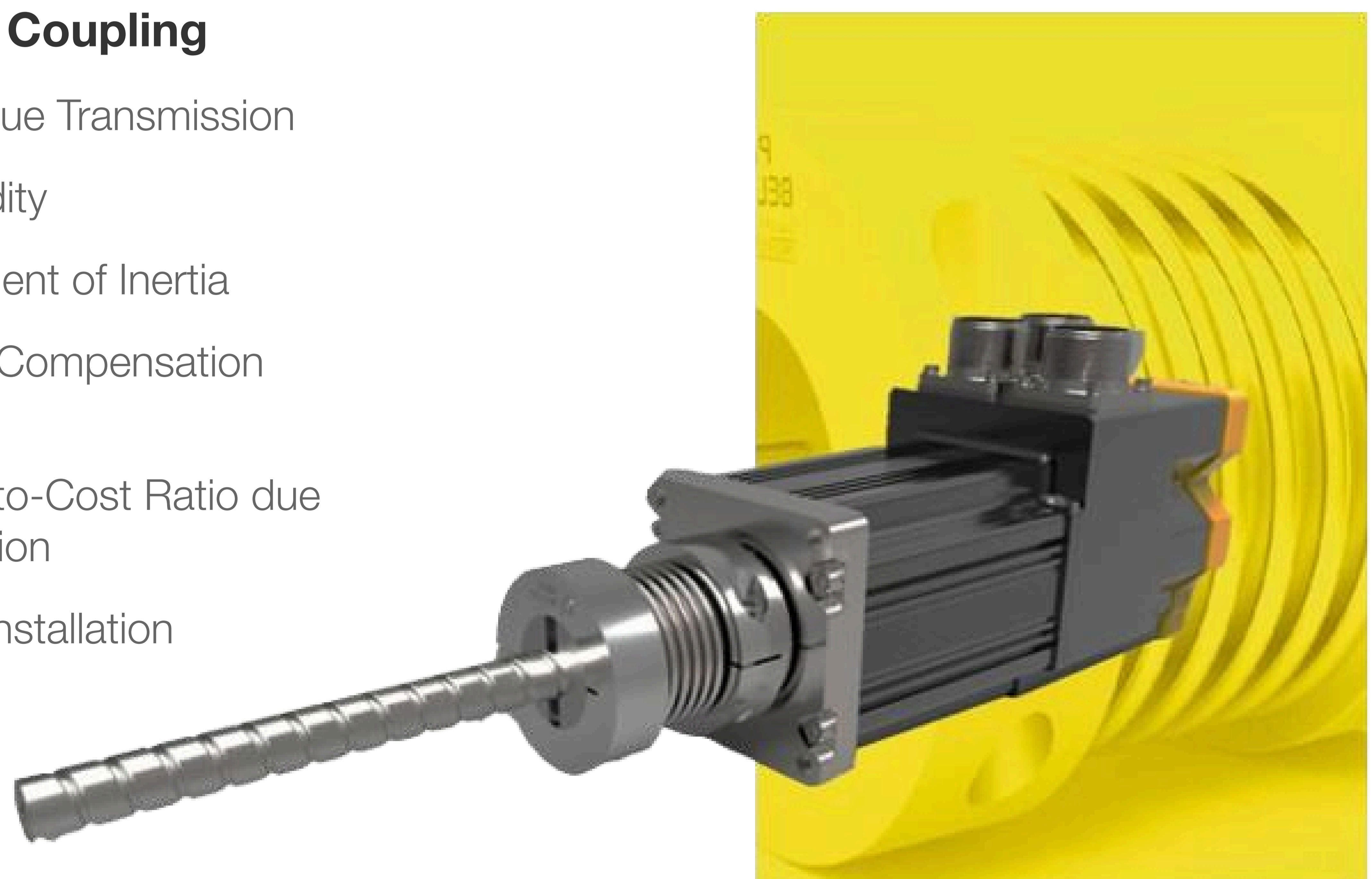

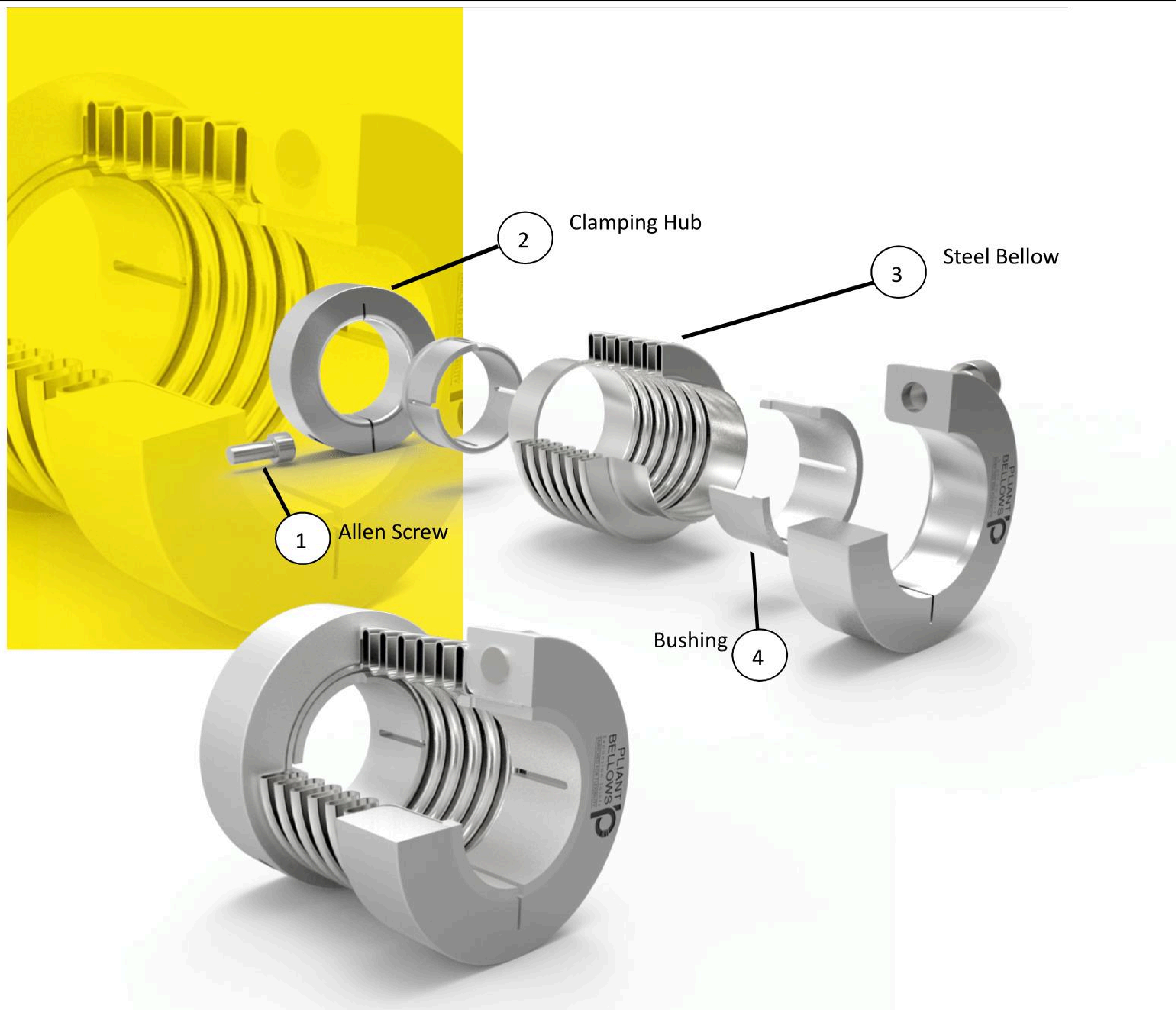

## Coupling Size Selection

When specifying flexible shaft couplings, the following key factors should always be considered:

### Torque

Although couplings are typically sized for the highest torque to be regularly transmitted, the peak torque of the application should not exceed the rated torque of the coupling. The following calculation provides an approximation of the minimum required coupling size for the application:

$T_N \times 1.5 \times T_{AS} \times T_N = \text{Rated Torque of the coupling (Nm)}$   
 $T_A = \text{Peak torque of the drive system (e.g. Breakdown Torque of the Electric motor)}$

## Misalignment Requirements

The maximum misalignment of shafts is the largest allowed displacement between the drive and output shafts, which results from the calculation of the prolonged alternating-stress strength for compensating elements. Determine the individual shaft misalignments, and by using the "Permitted Shaft Misalignments" mentioned in the table, find the intended coupling size.

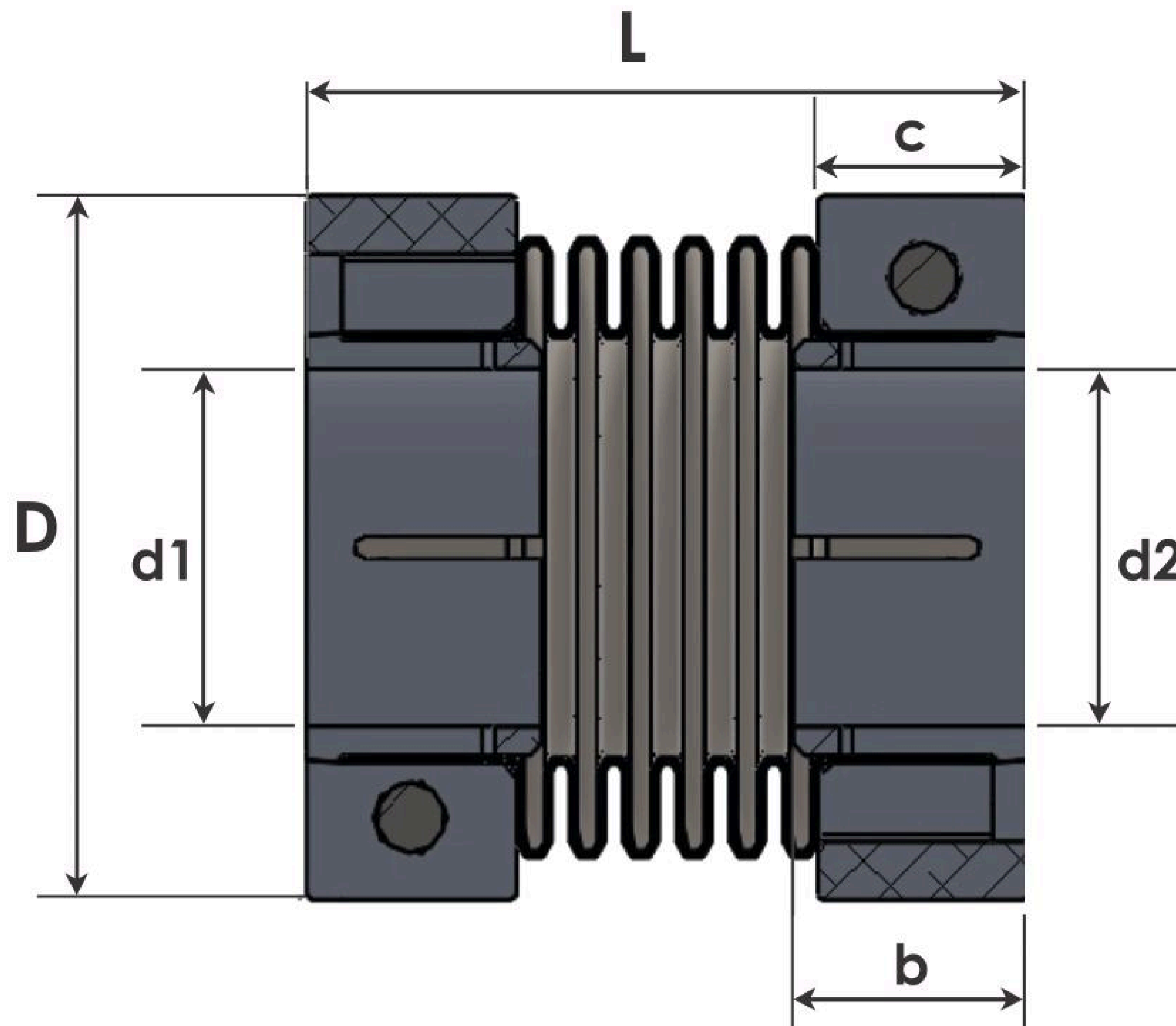

Part Number :

BC1	-	d1	-	d2	-	L	-	T	-	S
Bellow Coupling Series1		Shaft diameter Side 1 (mm)		Shaft diameter Side 2 (mm)		Length (mm)		Torque (Nm)		Speed (rpm)

Eg. : BC1 - 14 - 18 - 58 - 10 - 8000

## Metal Bellow Coupling

The metal bellow coupling is designed to be used in various torque transmission applications. The metal bellow perfectly compensates for axial, radial, and angular misalignments. The designed geometric shape of the steel bellow allows high torsional stiffness and a low mass moment of inertia. The Bellow Coupling is manufactured in five sizes for maximum torques up to 400 Nm.

The coupling steel bellows and clamping rings are the same for all the designs within a construction size. They are adapted via reducing bushings to the required shaft diameter. These bushings can be...

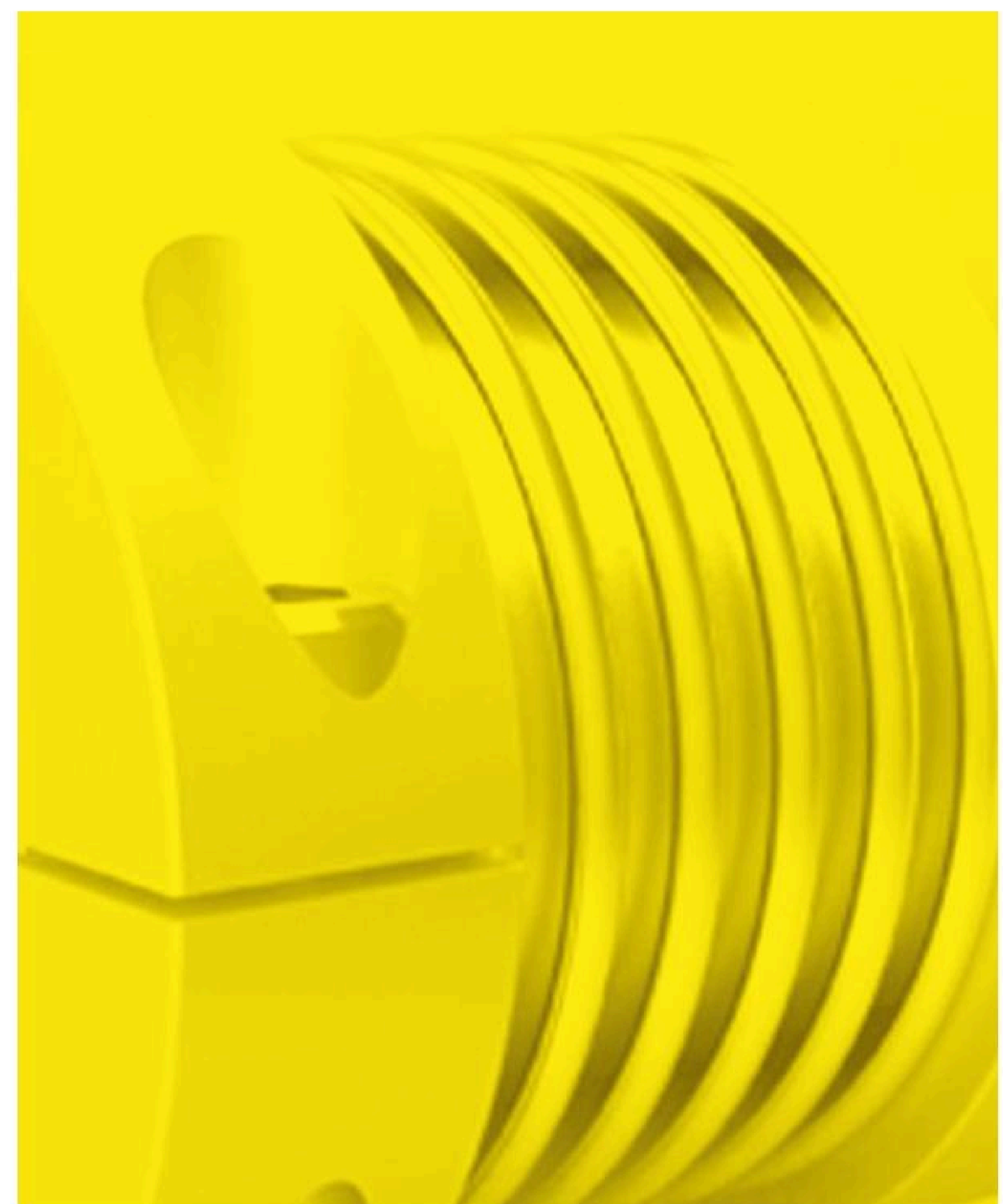



---

## Installing Couplings

### General Instructions-

1. Ensure that both shafts are free of burrs, damage, or foreign matter and can penetrate the bores.
2. Install the coupling by holding the shaft and the related hub, rotating it back and forth as you progress it along the shaft.
3. Do not apply any forces that cause extension, compression, or lateral displacement of the coupling.

### Installation Guidelines

1. Position and secure the larger of the two shafts (if different) and progress the coupling onto it.

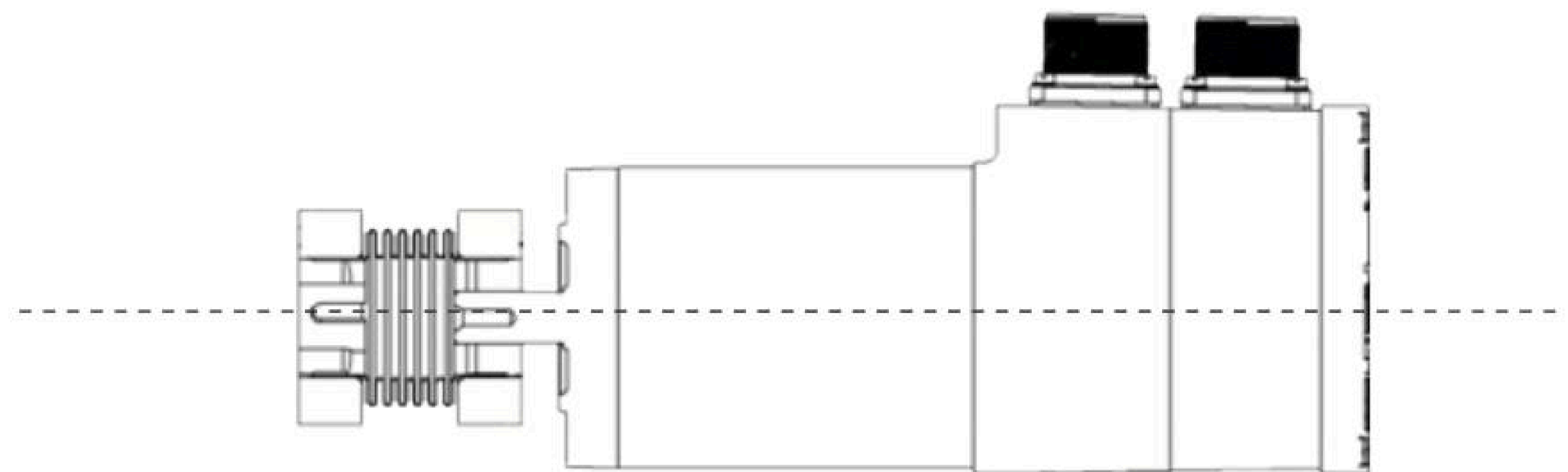

2. Progress the second shaft into the bore, taking care not to lever either shaft against the inner wall of the spacer.

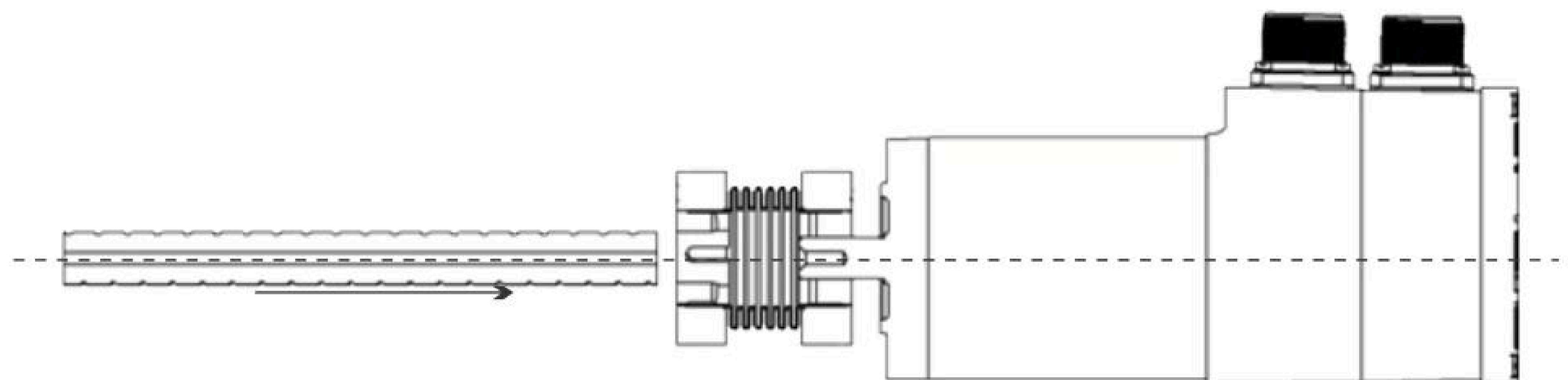

3. Progress the coupling along the shafts to a position midway between the shaft terminations. Rotate the coupling to ensure it is not binding and is in its natural state, i.e., neither extended nor compressed.

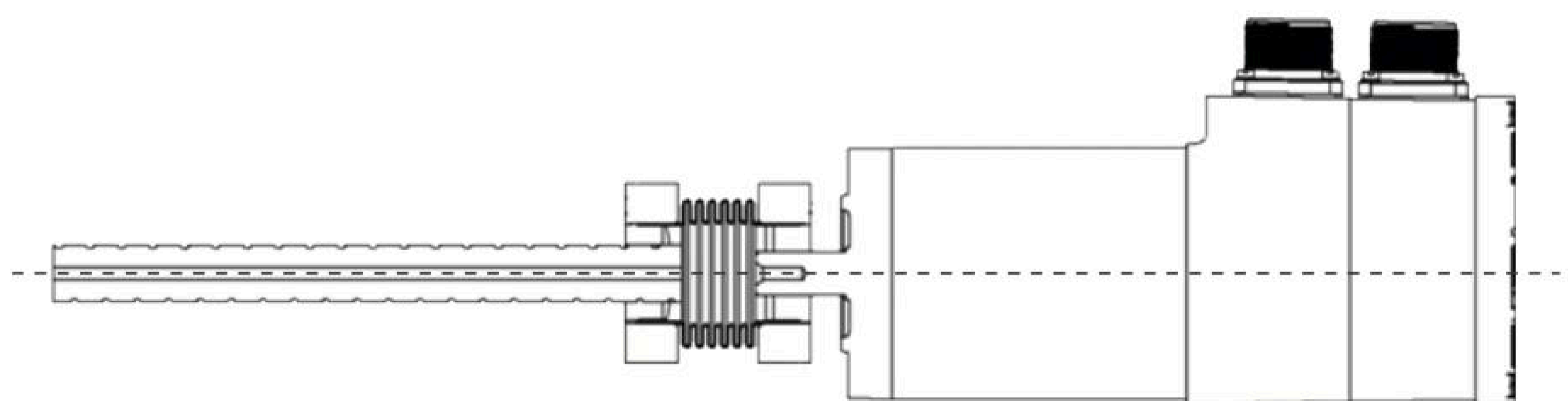

1. Align the second shaft with the first using a straight edge and feeler gauges or a dial indicator.
  2. Secure the second shaft and recheck alignment. Final alignment must be within the permissible offsets.
  3. Secure one hub, tightening each screw alternately. Repeat for the second hub.
-

# Design And Manufacturing

The company has excellent capabilities in design and manufacturing of metal bellow couplings. The bellow design calculations are done by using competent software like EJMA and backed by rich experience of our designers. Renowned software's like SolidWorks and ANSYS are used to design and validate the concept. Apart from software's the couplings are physically tested for the performance characteristics.

The company understands the importance of having a well equipped tool room and inspection facility to support its production activities. Hence the company has invested in conventional and CNC machines from lathes, grinding to vertical machining centres. For the production activity the organisation has focused on developing SPM's as it believes that SPM's will help in achieving consistency, reliability

Total Deformation 3  
Type: Total Deformation  
Unit: mm  
Time: 2

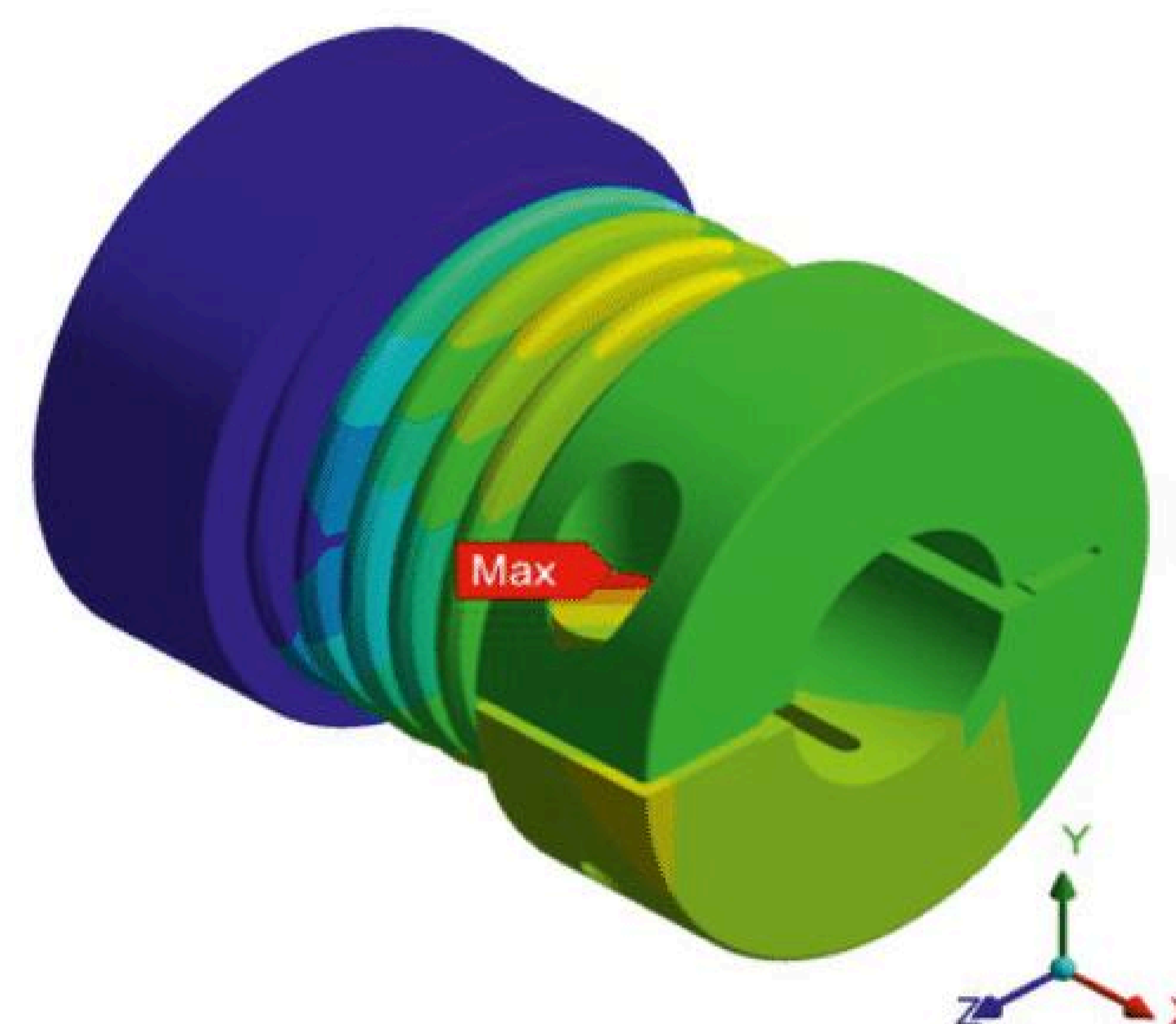
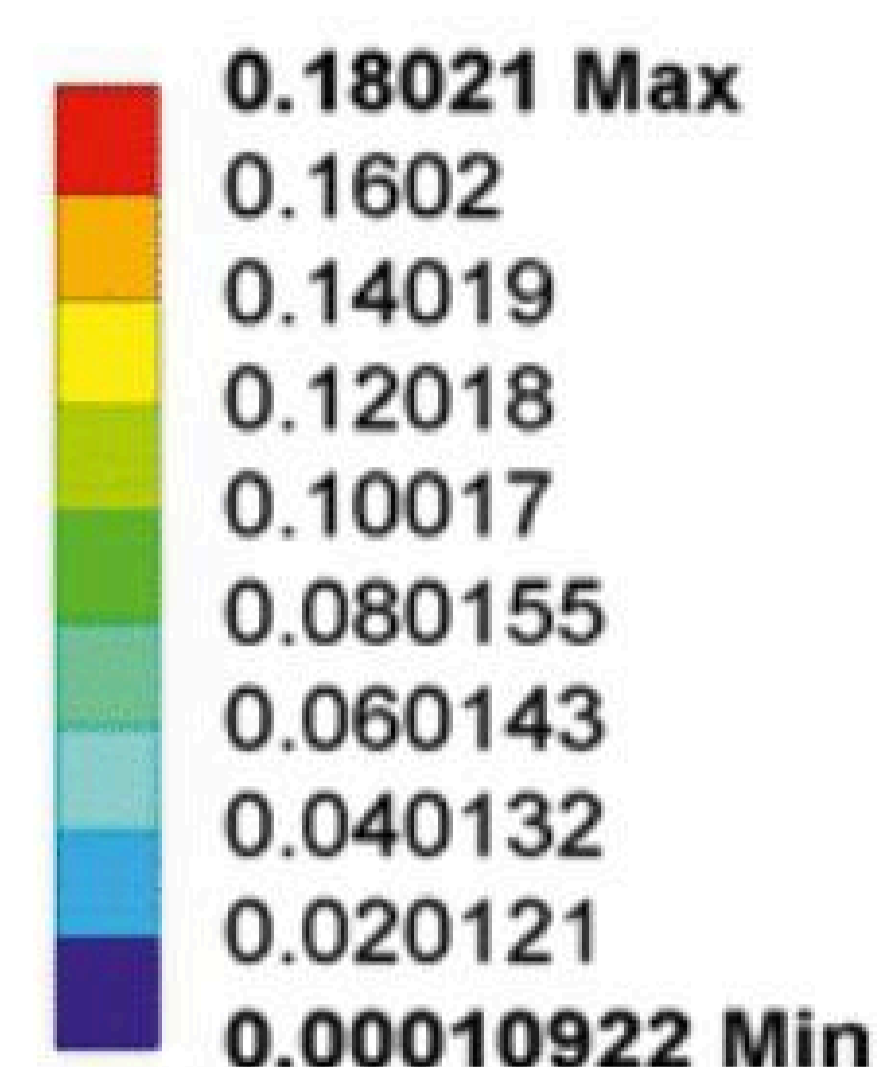

## Applications

- Power Generation
- Sugar Mill
- Infrastructure
- HVAC
- Cryogenic
- Steel Industries
- Measurement & Control Systems
- Oil & Gas
- Engine Exhaust
- Solar Technology
- Chemical Industries
- Instrument & Valve Industries
- Water/ Waste Water
- Nuclear Plant

## Testing Capabilities

- Hydrostatic Pressure and Leak Test
- Pneumatic Bubble Soap Leak Test
- Vacuum Test
- Dye Penetrant Test
- Visual Test
- Fatigue Test
- Squirm Test
- Spring Rate Test
- Radiography Test
- X-Ray Test
- Ultrasonic Test
- Helium Leak Detection

# Other Products

## Axial Expansion Joints

These joints are the simplest form of bellows manufactured. Pliant Bellows can manufacture them in single and multiple ply.



## Pressure Switch Bellows

Pressure switches are designed to make electrical contact when a set pressure is reached. These switches can be designed to close or open, based on the pressure rising or falling.



## Lateral Expansion Joints

Lateral expansion joints refer to the direction perpendicular to the centerline of the pipe expansion joint. Lateral deflection is also called Parallel Offset and Transverse. The lateral expansion joints are also known as tied lateral expansion joints.



## Hinged Expansion Joints

When the angular movement is only in one plane, hinge or angular expansion joints are used. An angular expansion can be expressed when an expansion joint experiences bending about its center, which is the centerline and halfway between the ends of the metal bellows.

---

## Inline Pressure Balanced Expansion Joints

An inline pressure balanced expansion joint accommodates axial and lateral movements and counteracts the bellows' pressure thrust.



## Pressure Balanced (Elbow) Expansion Joints

An elbow pressure balanced expansion joint is designed to absorb externally imposed axial movement without imposing pressure loading on the system.

## Universal Expansion Joints

Universal expansion joints are made up of two elements of bellows joined together by a common spool piece, so they are also called Double Bellows Expansion Joints or Universal Bellows.



## Gimbal Expansion Joints

Gimbal expansion joints are the most reliable expansion joints since they are capable of absorbing angular motion in all directions.

---

Customer: .....Sr.No: ..... Date: .....

Email Id: .....Mob. No.: .....PO No: .....

<b>Type of Bellow Couplings</b>	BC1.....BC2: .....BC3: ..... BC4: .....BC5: .....
<b>Bellow Material</b>	Material: .....No of Ply: ..... Ply Thickness: .....
<b>Bore Diameter</b>	d1(mm):..... d2(mm).....
<b>Length (L)</b>	In mm: .....
<b>Torque (T)</b>	In Nm :.....
<b>Speed (S)</b>	In rpm :.....
<b>Part Number</b>	BC Sr.No- dmin- dmax- Length- Torque- Speed

**Part Number Generation:**

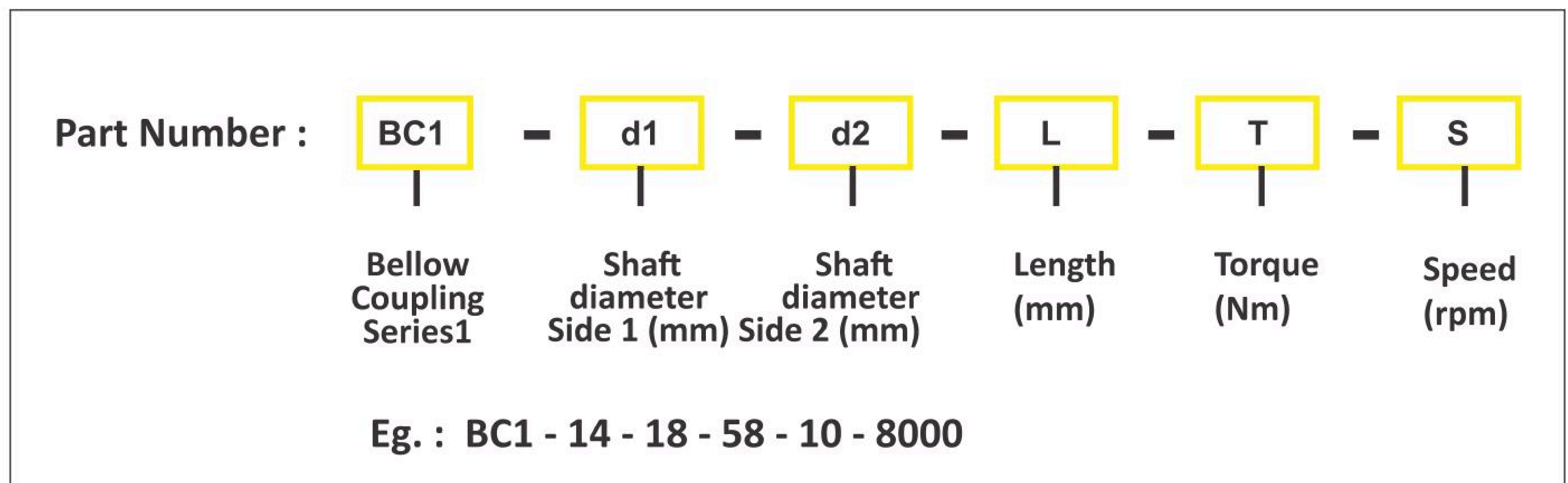

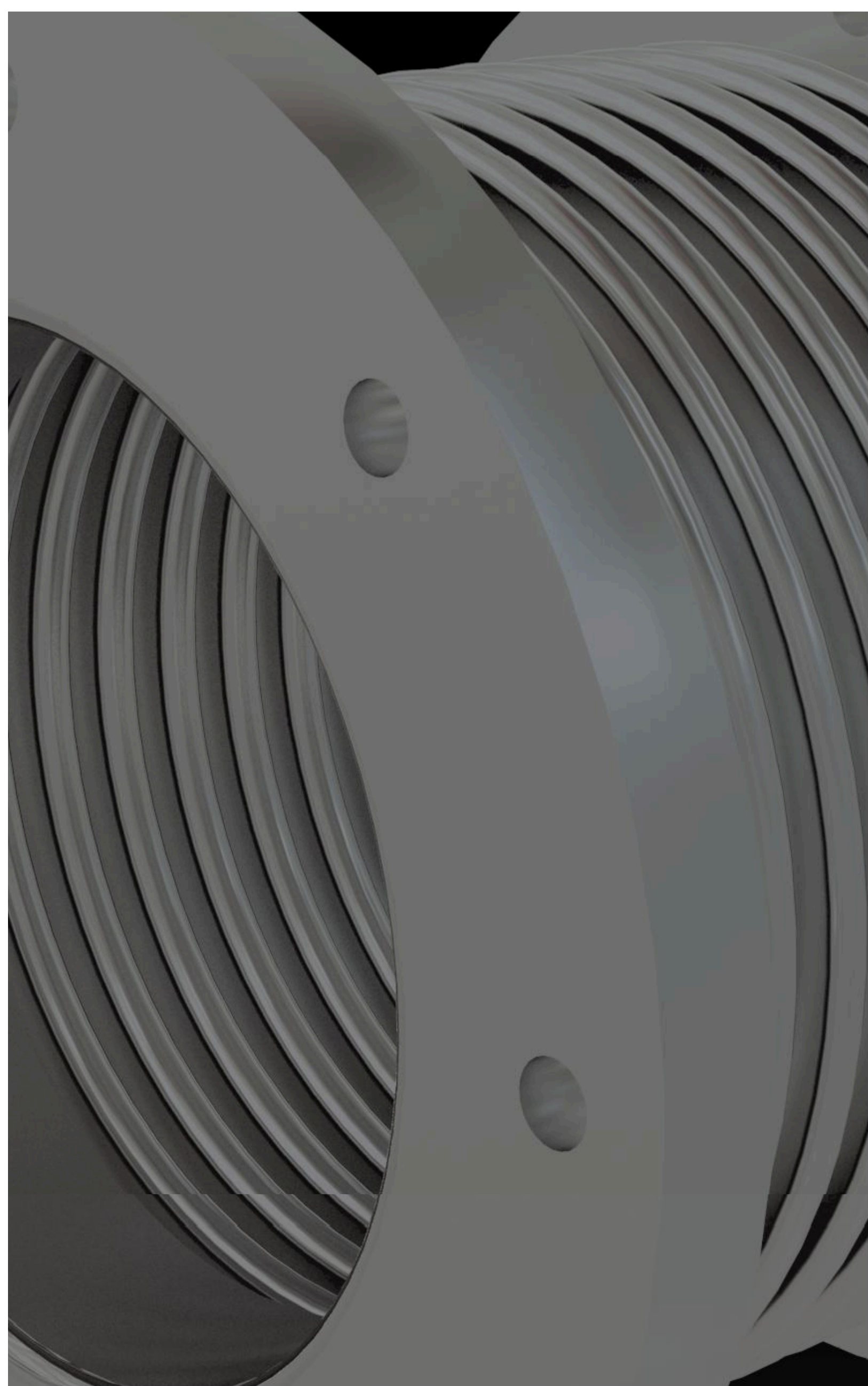
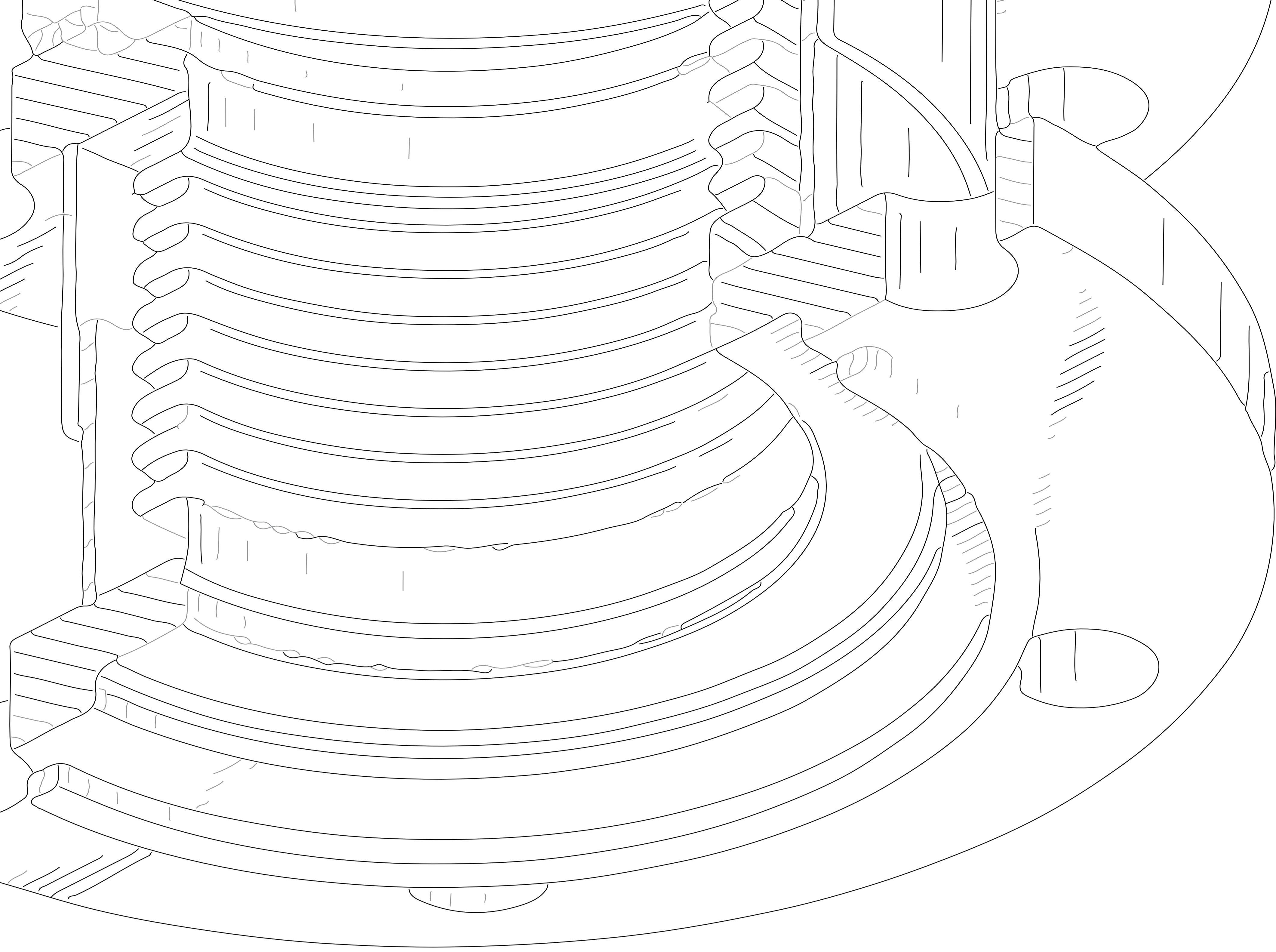



**FLEXORESIST TECHNOLOGIES PVT. LTD.**

ISO 9001:2015

### **Corporate Office**

Final plot no.38/1 Ramtekdi  
Industrial Estate, Hadapsar, Pune,  
Maharashtra, India- 411013

### **Phone**

+91-70289 97949  
+91-98904 54224  
+91-73876 43943

### **Email**

mktg@pliantbellows.com  
anand.uttarkar@flexoresist.com  
sales@flexoresist.com

**Website:** [www.pliantbellows.com](http://www.pliantbellows.com)

